

THIS DRAWING IS UNPUBLISHED. RELEASED FOR PUBLICATION ,19 .
 © COPYRIGHT 19 BY AMP INCORPORATED. ALL INTERNATIONAL RIGHTS RESERVED.

LOC		DIST		REVISIONS				DATE	APPD
ZONE	LTR	DESCRIPTION	DATE	APPD					
G	14	P	F	B	REV & REDRAWN PER 0720-0061-93	4-19-93	APPD		

METRIC
 DIMENSIONS LISTED IN mm [INCHES]

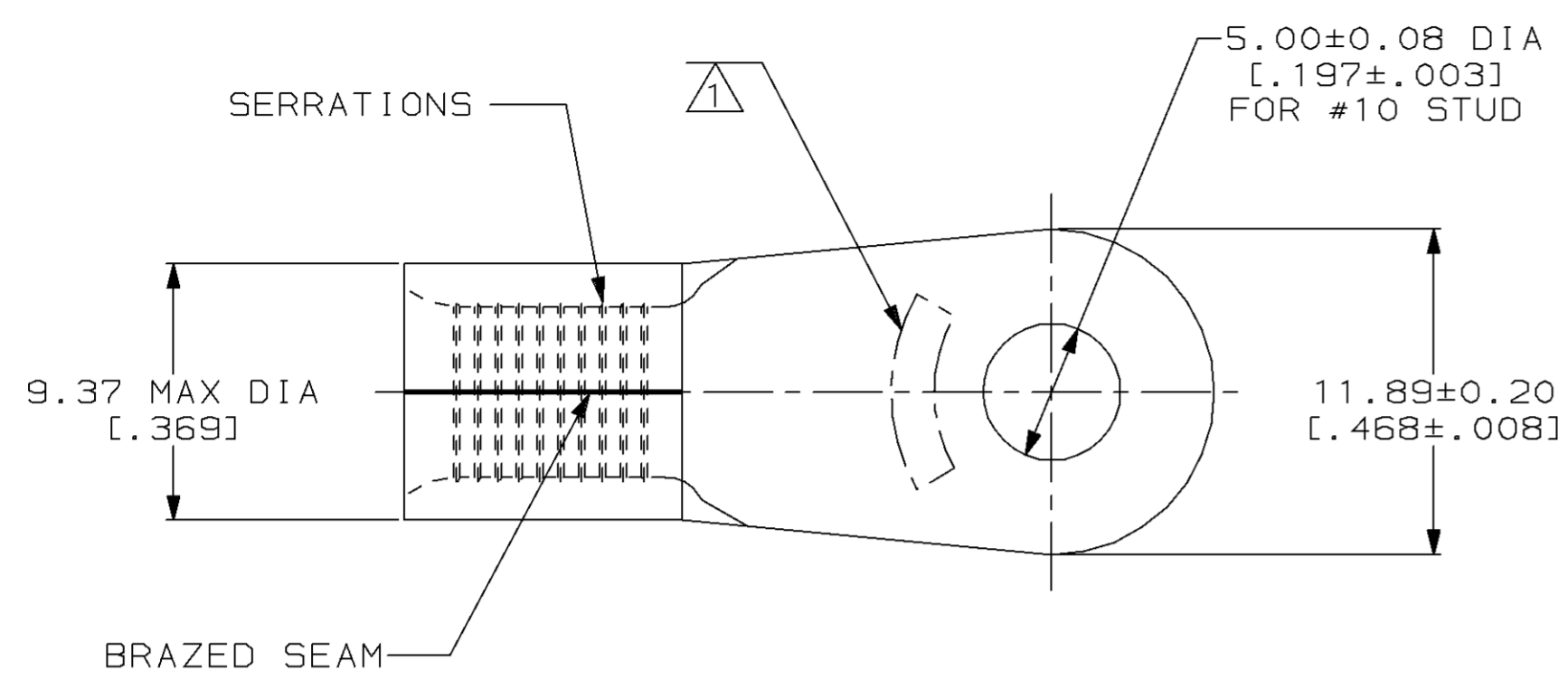

AMP WIRE RANGE	UL Listed
6 AWG SOLID OR STRANDED	NOT APPLICABLE
SR LR7189 Certified	MILITARY P/N AND CLASS
NOT APPLICABLE	NOT APPLICABLE

△ STAMP AMP 6* APPROX AS SHOWN

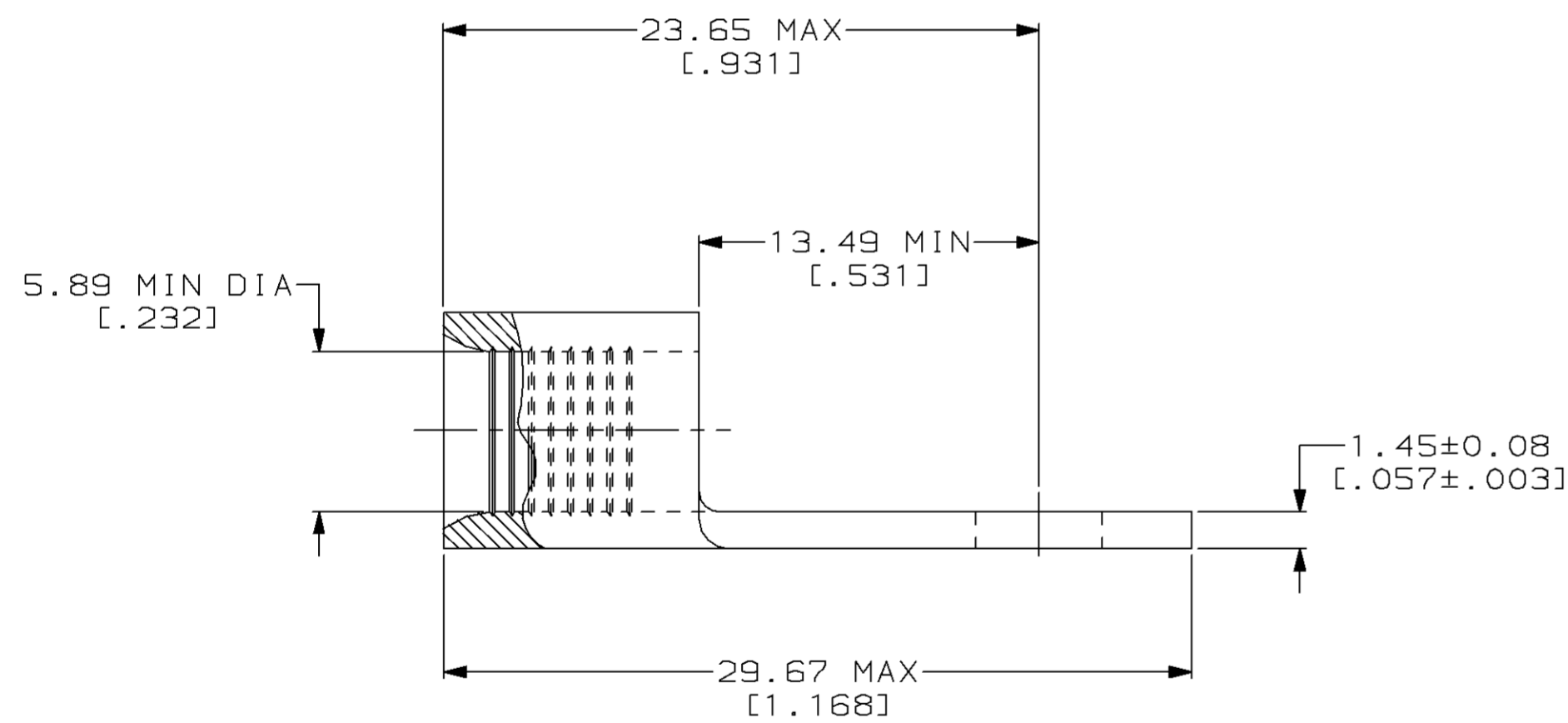

323169

PART NO

AMP INCORPORATED
CUSTOMER SERVICE SYSTEMS

MAX RECOMMENDED OPERATING TEMPERATURE:
 343°C MAX

DO NOT SCALE PRINT.
 UNLESS SPECIFIED
 DIMENSIONS IN mm [INCHES]
 TOLERANCES ON:
 2 PLC DEC ± -
 3 PLC DEC ± -
 ANGLES ± -

DR 4-19-93
 TA BRINKMAN
 CHK 4-19-93
 DA PATTERSON
 APPD 4-19-93
 DE MILLER
 APPD 4-19-93
 JL MECKLEY

AMP AMP Incorporated
 Harrisburg, PA 17105-3608

FOR ADDITIONAL
 PRODUCT INFORMATION OR
 COPIES OF DRAWINGS
 AND TECHNICAL DOCUMENTS

PRODUCT INFORMATION CENTER
 1-800-522-6752

VOLTAGE RATING:
 NOT APPLICABLE

MATERIAL
 COPPER PER
 ASTM B-152
 ANNEALED

NAME
 TERMINAL, RING TONGUE,
 HEAT RESISTANT,
 STRATO-THERM™

FOR APPLICATION
 TOOLING INFORMATION

TOOLING ASSISTANCE CENTER
 1-800-722-1111

WIRE CROSS SECTIONAL AREA RANGE:
 10.5-16.8MM² [20,800-33,100] CIR MILS
 SOLID OR STRANDED

FINISH
 NICKEL PLATE
 0.00762[.000300] MIN
 THK PER QQ-N-290

APPLICATION SPEC
 -
 WEIGHT -

SIZE
 CAGE CODE
 DRAWING NO
 SCALE 4:1
 00779
 C=323169
 SHEET 1 OF 1

FOR ORDER ENTRY
 1-800-526-5142

THIS DRAWING IS A CONTROLLED DOCUMENT FOR
 AMP INCORPORATED. IT IS SUBJECT TO CHANGE
 AND THE CONTROLLING ENGINEERING ORGANIZATION
 SHOULD BE CONTACTED FOR THE LATEST REVISION.